

CPKF SERIES 50 Hz

SPLIT SYSTEM HEAT PUMP

2 TO 5 TON
[7.0 KW TO 17.56 KW]

NOMINAL CAPACITY
24,000 TO 60,000 BTU/H



This 50-Hz split system heat pump allows for ground-level or rooftop applications and has been tested for optimum performance by an independent third party.

Standard Features

- Quiet operating top discharge
- Copper tube/aluminum fin coil
- Brass suction and liquid line shut-off valves with sweat connection
- Manual reset high-pressure control
- Automatic reset low-pressure control for loss-of-charge protection
- Totally enclosed, permanently lubricated condenser motor
- Ultra-quiet hermetically sealed compressor with internal high-pressure control
- Bi-flow liquid line filter dryer
- Suction line accumulator
- Check flowrator expansion device
- Anti-cycling reversing valve circuit
- Crankcase heater (where indicated)
- Time-initiated, temperature-terminated defrost control
- Contactor with lug connections
- Ground lug connections
- CE Certified

Cabinet Features

- Unique Goodman® sound control design
- Heavy-gauge, galvanized-steel cabinet properly reinforced and braced
- Steel louver coil guard
- Attractive architectural gray powder-paint finish with 500-hour salt spray approval
- Removable access panels

Air Handler Compatibilities

- Designed for use with A Series air handlers
- A Series air handlers may be located in a closet, utility room, attic, or basement

Accessories

- Room thermostat with 2-stage heat/1-stage cool and emergency heat, capability (HPT18-60)
- Automatic change-over room thermostat with 2-stage heat/1-stage cool and emergency heat capability (HPTA18-60)
- Digital Room Thermostat for 2-stage heat/1-stage cool (CTHP18-60HD)

PRODUCT SPECIFICATIONS

NOMENCLATURE

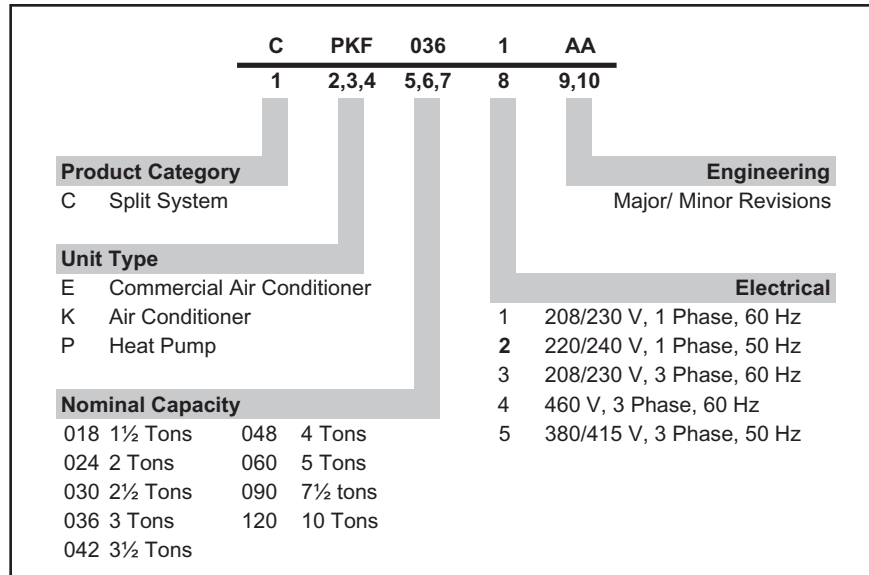

PERFORMANCE RATINGS

Model #	Coil / Air Handler	Cooling Capacity (BTU/h)				Heating Capacity (BTU/h)					dBs
		Total	Sensible	EER ¹	kWI ²	47°F	47°F COP	HSPF ³	17°F	17°F COP	
CPKF24-2*	A24-00-2RA	23,400	16,400	9.0	2.60	23,000	2.8	7.0	12,400	2.00	78
CPKF36-2/5*	A36-00-2RA	33,000	24,100	9.0	3.67	32,000	2.9	7.2	17,400	2.00	78
	A48-00-2RA	35,000	25,900	9.0	3.89	32,000	3.0	7.5	19,000	2.30	78
CPKF42-5*	A48-00-2RA	40,000	30,700	9.0	4.44	39,000	3.1	7.8	21,400	2.00	78
CPKF48-5*	A48-00-2RA	48,000	34,600	9.0	5.33	48,000	3.3	8.2	29,600	2.30	78
CPKF60-5*	A60-00-2RA	53,000	36,600	9.0	5.89	54,000	3.2	8.0	35,400	2.10	80
CPKF61-5*	A60-00-2RA	57,000	38,800	9.0	6.33	61,000	3.0	8.0	37,800	2.20	80

¹ Energy Efficiency Ratio @ 80°F / 67°F / 95°F

² kWI = Compressor + Indoor Blower + Outdoor Fan Watts

³ HSPF = Heating Seasonal Performance Factor

Note: When mix-matching outdoor and indoor units, the indoor unit check-flowrator must match the outdoor unit size.

SPECIFICATIONS

	CPKF24-2*	CPKF36-2*	CPKF36-5*	CPKF42-5*	CPKF48-5*	CPKF60-5*	CPKF61-5*
Capacities							
Nominal Cooling (BTU/h)	23,600	33,000	35,000	40,000	48,000	53,000	57,000
EER ¹	9.0	9.0	9.0	9.0	9.0	9.0	9.0
Nominal Heating (BTU/h)	23,000	32,000	32,000	39,000	48,000	54,000	61,000
Decibels	78	78	78	78	78	80	80
Compressor							
RLA	12.2	17.9	5.3	7.4	9.0	9.0	10.9
LRA	64	97.4	42	50	65.5	74	101
Volts	220-240	220-240	380-420	380-420	380-420	380-420	380-420
Condenser Fan Motor							
Horsepower	¼	¼	⅓	¼	⅓	⅓	⅓
FLA	0.9	0.9	1.2	0.8	1.2	1.2	1.2
Volts	220-240	220-240	380	380	380	380	380
Refrigeration System							
Liquid Valve Size ("O.D.)	3/8	3/8	3/8	3/8	3/8	3/8	3/8
Suction Valve Size ("O.D.)	¾	¾	¾	⅞	⅞	⅞	⅞
Valve Type	Sweat	Sweat	Sweat	Sweat	Sweat	Sweat	Sweat
Refrigerant Charge (oz.)	72	110	110	131	137	138	167
Shipped with Orifice Size (in.)	0.059	0.073	0.073	0.080	0.084	0.093	0.093
Condenser Fan / Coil							
Horsepower - RPM	¼-950	¼-950	⅓-1075	¼-950	⅓-1075	⅓-1075	⅓-1075
Fan Diameter/ # Fan Blades	20/3	20/3	20/3	22/3	22/3	22/3	22/3
Outdoor Nominal CFM	1800	1800	1800	2600	2600	2600	3200
Face Area (ft ²)	13.3	14.58	14.58	14.58	17	17	1
Rows Deep/ Fins per Inch	1/19	1/19	1/19	1/19	1/19	1/22	1/22
Fin Type	Ripple	Ripple	Ripple	Ripple	Ripple	Ripple	Ripple
Coil No. of Tubes	22	24	24	24	24	36	36
Coil Tube Diameter (in.)	0.375	0.375	0.375	0.375	0.375	0.375	0.375
Electrical Data							
Voltage-Hz / Phase	220/240-50/1			380/415-50/3			
Min. Circuit Ampacity ²	16.2	23.3	7.9	10	12.4	12.4	14.8
Max. Overcurrent Protection (amps) ³	25	40	15	15	20	20	20
Min / Max Volts	198/264	198/264	342/456	342/456	342/456	342/456	342/456
Power Supply Conduit Size	½ or ¾	½ or ¾	½ or ¾	½ or ¾	½ or ¾	½ or ¾	½ or ¾
Ship Weight (lbs-[kg])	191 (87)	206 (94)	206 (94)	213 (97)	216 (98)	248 (113)	249 (113)

¹ Energy Efficiency Ratio

² Wire size should be determined in accordance with National Electrical Codes. Extensive wire runs will require larger wire sizes.

³ Must use time-delay fuses or HACR-type circuit breakers of the same size as noted.

Note: Always check the S&R plate for electrical data on the unit being installed.

DIMENSIONS

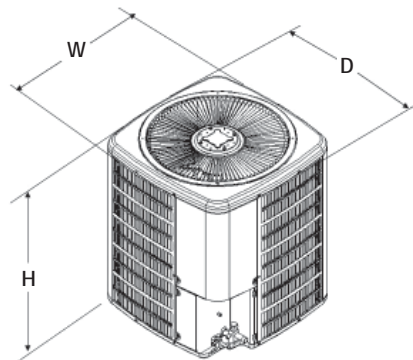

Model	Width	Depth	Height
CPKF24-2*	26	26	29¼
CPKF36-2/5*	26	26	32¼
CPKF42-5*	29	29	32¼
CPKF48-5*	29	29	32¼
CPKF60-5*	29	29	38¼
CPKF61-5*	29	29	38¼

PRODUCT SPECIFICATIONS

SCHEMATIC WIRING DIAGRAMS

LOW-VOLTAGE CONTROL WIRING DIAGRAM

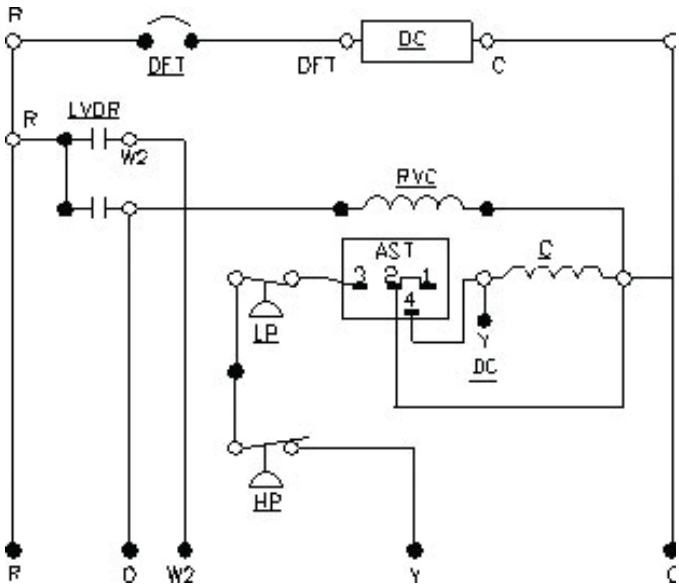

Component Code

- CM - Outdoor Fan Motor
- COMP - Compressor
- C - Contactor
- DC - Defrost Control
- LDVR - Low-Voltage Defrost Relay
- CH - Crankcase Heater
- IO - Internal Overload
- LP - Low-Pressure Control
- HP - High-Pressure Control
- OT - Outdoor Thermostat (Optional)
- FC - Fan Capacitor
- DFT - Defrost Thermostat
- RVC - Reversing Valve Coil
- HVDR - High-Voltage Defrost Relay
- AST - Anti-Short Cycle Timer

LINE-VOLTAGE POWER WIRING DIAGRAMS

380/415, 50 HZ, 3 PH

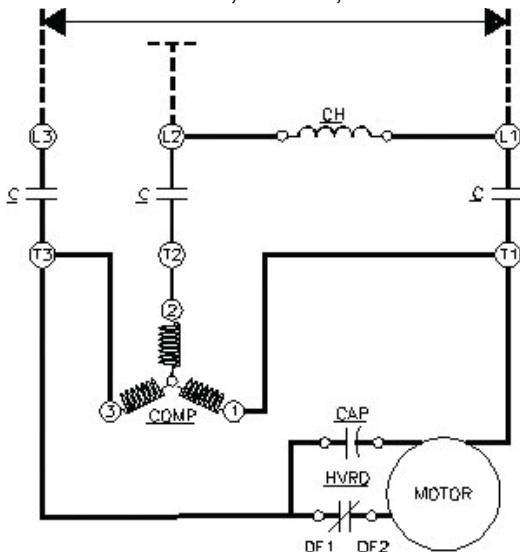

CPKF36-5, CPKF48-5, CPKF60-5 & CPKF61-5

220/240, 50HZ, 1 PH

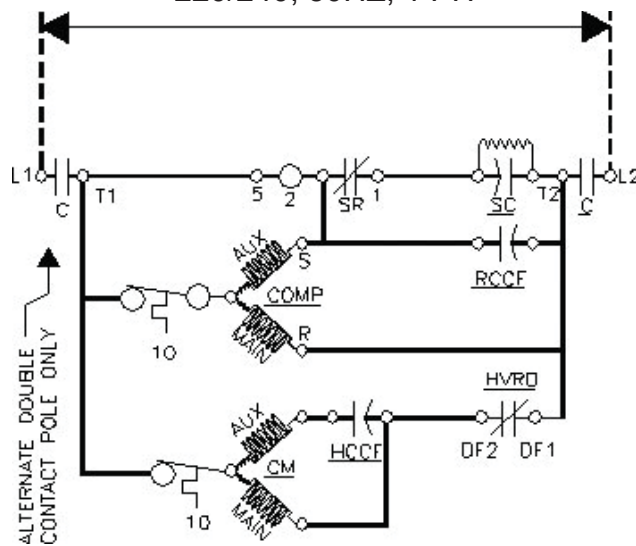

CPKF24-2, CPKF36-2 & CPKF48-2

QUALITY MAKES THE DIFFERENCE!

All of our systems are designed and manufactured with the same high-quality standards, regardless of size or efficiency. We have designed these units to significantly reduce the most frequent causes of product failure and use quality materials and components. They are simple to service and forgiving to operate. Finally, every unit is run-tested before it leaves the factory. That's why we know... there's no better quality.

Visit our website at www.goodmanmfg.com for information on: Goodman Products • Customer Services • Parts

Goodman Manufacturing Company, L.P., reserves the right to discontinue, or change at any time, specifications or designs without notice or without incurring obligations. Copyright © 2007 Goodman Manufacturing Company, L.P. • Houston, Texas • Printed in the USA.